



# Christian County Commission

100 West Church St, Room 100  
Ozark, MO 65721

October Term

<http://ChristianCountyMO.iqm2.com>

~ Minutes ~

Thursday, February 25, 2016

8:50 AM

The Christian County Courthouse

## I. Convene

The meeting was called to order at 8:50 AM by Presiding Commissioner Ray Weter

### A. Roll Call

Attendee Name	Title	Status	Arrived
Ray Weter	Presiding Commissioner	Present	8:50 AM
Bill Barnett	Western Commissioner	Present	8:50 AM
Sue Ann Childers	Eastern Commissioner	Present	8:50 AM
Kay Brown	County Clerk	Present	8:50 AM
Norma Ryan	Chief Deputy County Clerk	Present	8:50 AM
Ashley Hannah	Secretary	Present	8:50 AM

## II. Agenda

### **Motion/Vote - 8:54 AM Christian County Commission**

Discussion - Approve Agenda

The meeting was attended by Commission Secretary Ashley Hannah, Hosea Bilyeu, and Kent John and Judy Dollarhite.

Commissioner Weter entertained a motion to approve the published agenda for Thursday, February 25, 2016

<b>RESULT:</b>	<b>ADOPTED [UNANIMOUS]</b>
<b>MOVER:</b>	Sue Ann Childers, Eastern Commissioner
<b>SECONDER:</b>	Bill Barnett, Western Commissioner
<b>AYES:</b>	Ray Weter, Bill Barnett, Sue Ann Childers

### **Motion/Vote - 8:55 AM Kay Brown-County Clerk**

Minutes & Financials Approval - Approve Minutes & Financials

The meeting was attended by Commission Secretary Ashley Hannah, Hosea Bilyeu, Kent John and Judy Dollarhite.

Commissioner Weter entertained a motion to approve the Feb. 4, 2016 minutes.

<b>RESULT:</b>	<b>ADOPTED [UNANIMOUS]</b>
<b>MOVER:</b>	Bill Barnett, Western Commissioner
<b>SECONDER:</b>	Sue Ann Childers, Eastern Commissioner
<b>AYES:</b>	Ray Weter, Bill Barnett, Sue Ann Childers

**Motion/Vote - 8:56 AM**

Approve the February 4, 2016 Closed And Open Session Minutes

The meeting was attended by Commission Secretary Ashley Hannah, Hosea Bilyeu, Kent Johns and Judy Dollarhite.

Commissioner Weter entertained a motion to approve the Feb. 4, 2016, closed and open session minutes.

<b>RESULT:</b>	<b>ADOPTED [UNANIMOUS]</b>
<b>MOVER:</b>	Sue Ann Childers, Eastern Commissioner
<b>SECONDER:</b>	Bill Barnett, Western Commissioner
<b>AYES:</b>	Ray Weter, Bill Barnett, Sue Ann Childers

**Motion/Vote - 8:57 AM**

Approve the Open Minutes for February 22, 2016

The meeting was attended by Commission Secretary Ashley Hannah, Hosea Bilyeu, Kent John and Judy Dollarhite.

Commissioner Weter entertained a motion to approve the open minutes for February 22, 2016.

<b>RESULT:</b>	<b>ADOPTED [UNANIMOUS]</b>
<b>MOVER:</b>	Bill Barnett, Western Commissioner
<b>SECONDER:</b>	Sue Ann Childers, Eastern Commissioner
<b>AYES:</b>	Ray Weter, Bill Barnett, Sue Ann Childers

**Motion/Vote - 8:58 AM**

Approve the Closed Session Minutes for February 22, 2016

The meeting was attended by Commission Secretary Ashley Hannah, Hosea Bilyeu, Kent John and Judy Dollarhite.

Commissioner Weter entertained a motion to approve the closed session minutes for February 22, 2016.

<b>RESULT:</b>	<b>ADOPTED [UNANIMOUS]</b>
<b>MOVER:</b>	Sue Ann Childers, Eastern Commissioner
<b>SECONDER:</b>	Bill Barnett, Western Commissioner
<b>AYES:</b>	Ray Weter, Bill Barnett, Sue Ann Childers

**Motion/Vote -**

Approve CART Court Order # 02-25-2016-1

The meeting was attended by Commission Secretary Ashley Hannah, Hosea Bilyeu, Kent John and Judy Dollarhite.

Commissioner Weter entertained a motion to approve the C.A.R.T. Court Order #02-25-2016-1 in the amount of \$ 119,111.69.

<b>RESULT:</b>	<b>ADOPTED [UNANIMOUS]</b>
<b>MOVER:</b>	Bill Barnett, Western Commissioner
<b>SECONDER:</b>	Sue Ann Childers, Eastern Commissioner
<b>AYES:</b>	Ray Weter, Bill Barnett, Sue Ann Childers

**Motion/Vote - 9:00 AM      Todd Wiesehan-Planning & Development**

Bid Decision - Bid Decision-Color Digital Imaging System

The meeting was attended by Todd Wiesehan, Hosea Bilyeu, Judy Dollarhite, and Kent Johns representative for American Business Systems.

Todd Wiesehan said there were four bids received representing two proposals each for two different machines. Todd Wiesehan said the purchase prices range from \$ 6307.00 to \$ 7,650.00. Todd said the major difference is the on-going maintenance costs between American Business Systems and Corporate Business Systems. The long term maintenance costs differ based on the amount of use versus a monthly flat rate. Mr. Wiesehan said Corporate Business System offered the lowest purchase price as well as the lowest cost for long term maintenance based on usage rather than a monthly flat rate.

Presiding Commissioner Ray Weter entertained a motion to award the purchase of the MP CW2200 copier purchase to Corporate Business Systems in the amount of \$ 6,451.00, as recommended by Planning and Zoning Administrator Todd Wiesehan.

<b>RESULT:</b>	<b>ADOPTED [UNANIMOUS]</b>
<b>MOVER:</b>	Sue Ann Childers, Eastern Commissioner
<b>SECONDER:</b>	Bill Barnett, Western Commissioner
<b>AYES:</b>	Ray Weter, Bill Barnett, Sue Ann Childers

**Motion/Vote - 9:15 AM      Christian County Commission**

Discussion - Adoption of Resolution-Grievance Procedures & Employee Handbook Revision

The meeting was attended by Commission Secretary Ashley Hannah, Hosea Bilyeu, Judy Dollarhite, Miranda Beadles, Treasurer Karen Matthews, Mary Argisio and Jeremy Parsons Planning and Development Director for the City of Ozark.

The County Commission was notified the Community Development Block Grant for Chadwick School requires a resolution be adopted by Christian County titled "Section 504/ADA Policy & Grievance Procedure" . This resolution is required to be in compliance with the federal government to obtain public funds.

Presiding Commissioner Weter said this is a standard grievance policy written by County Counselor John Housley to comply with the requirements of the Community Development Block Grant.

Treasurer Karen Matthews asked what does the resolution actually say?

Presiding Commissioner Ray Weter read the preamble of the resolution. Commissioner Weter said this policy and the Code of Ethics will be incorporated into the employee handbook and will be posted in a prominent place in the Courthouse.

Presiding Commissioner Ray Weter called for a motion to approve, sign and implement Resolution NO. 2-25-2016-1 into the employee handbook and post it in the courthouse.

<b>RESULT:</b>	<b>ADOPTED [UNANIMOUS]</b>
<b>MOVER:</b>	Bill Barnett, Western Commissioner
<b>SECONDER:</b>	Sue Ann Childers, Eastern Commissioner
<b>AYES:</b>	Ray Weter, Bill Barnett, Sue Ann Childers

**Motion/Vote - 9:30 AM City of Ozark**

Discussion - Square Beautification

The meeting was attended by Commission Secretary Ashley Hannah, Hosea Bilyeu, Judy Dollarhite, Miranda Beadles, Amelia Wigdon reporter for the Christian County Headliner News and Jeremy Parsons Planning and Development Director of the City of Ozark.

The County Commission met with Jeremy Parsons, Planning and Development Director for the City of Ozark regarding a beautification proposal for the City's square from The Dream Initiative. Mr. Parsons said the grant is approximately \$ 1,500.00, and they are planning to construct a kiosk on the Northwest corner of the square.

Mr. Parsons said the kiosk will bring potential economic development and will act as a way finder from the information on the kiosk. They had researched the civil war and noted that the City of Ozark, particularly the mill, served as a supply station for the Union Soldiers to stop the advance from the south.

Mr. Parsons said the design of the kiosk is well built and very attractive and will not affect any future utilities or the loss of any parking spaces at the site.

Mr. Parsons said he is here today to receive the Commission's blessing to build the kiosk on the courthouse square.

Miranda Beadles said they would like to have a courtesy review of the plans prior to building the kiosk.

Presiding Commissioner Ray Weter entertained a motion to indicate Commission approval of the Ozark's Square Beautification proposal and to support this project.

<b>RESULT:</b>	<b>ADOPTED [UNANIMOUS]</b>
<b>MOVER:</b>	Sue Ann Childers, Eastern Commissioner
<b>SECONDER:</b>	Bill Barnett, Western Commissioner
<b>AYES:</b>	Ray Weter, Bill Barnett, Sue Ann Childers

### III. Adjournment

The meeting was closed at 10:10 AM

**Motion/Vote -**

Adjourn

The schedule meeting of the County Commission for February 25th, 2016, have been completed. The County Commission will reconvene on Monday, February 29th, 2016.

<b>RESULT:</b>	<b>ADOPTED [UNANIMOUS]</b>
<b>MOVER:</b>	Sue Ann Childers, Eastern Commissioner
<b>SECONDER:</b>	Bill Barnett, Western Commissioner
<b>AYES:</b>	Ray Weter, Bill Barnett, Sue Ann Childers



Ray Weter

Presiding Commissioner, Ray Weter



Bill Barnett

Western Commissioner, Bill Barnett



A handwritten signature in black ink that reads "Sue Ann Childers". The signature is written in a cursive, flowing style.

---

Sue Ann Childers

Eastern Commissioner, Sue Ann Childers

CERTIFIED COURT ORDER # 02-25-2016-1

The Treasurer is hereby ordered to pay the following entities:

RECEIVED  
 NR  
 FEB 24 2016  
 3:12

February 2016 Cart January 2016 Term  
 KAY BROWN  
 COUNTY CLERK

RECEIPT: 26460				
DATE: February 24, 2016				
AMOUNT RECEIVED		295-420-221	119,111.69	Check #
BRIDGE		15.00%	17,866.75	
	ROAD MILES			
COMMON 1	297.51	29.67%	35,340.44	
COMMON 2	280.69	27.99%	33,339.36	
BILLINGS SPECIAL	103.25	10.30%	12,268.50	
GARRISON SPECIAL	24	2.39%	2,846.77	
OZARK SPECIAL	102.97	10.27%	12,232.78	
SELMORE SPECIAL	27.5	2.74%	3,263.66	
SOUTH SPARTA SPECIAL	11.1	1.11%	1,322.14	
STONESHIRE SPECIAL	5.3	0.53%	631.29	
TOTAL ROADS	852.32	100.00%	101,244.94	
TOTAL BRIDGE			17,866.75	
TOTAL DISBURSED			119,111.69	

*Ray Weter*  
 Presiding Commissioner Ray Weter

*Bill Barnett*  
 Western Commissioner Bill Barnett

*Sue Ann Childers*  
 Eastern Commissioner Sue Ann Childers

IN TESTIMONY WHEREOF, I have hereunto set my hand and affixed the seal of said Commission, at my office in Christian County this the 25th day of February, 2016.

*Kay Brown*  
 Kay Brown, Clerk of the County Commission



# CHRISTIAN COUNTY COMMISSION

100 W Church Street, Room 100  
Ozark, Missouri 65721  
Phone: 417-582-4300 • Fax: 471-581-5924

**Ray Weter**  
Presiding Commissioner

**Bill Barnett**  
Western Commissioner

**Sue Ann Childers**  
Eastern Commissioner

February 25<sup>th</sup>, 2016

Jerry Teal  
Corporate Business Systems  
3348 E. Cherry  
Springfield, MO 65803

Dear Jerry,

The Christian County Commission voted today in session to award the bid for a Digital Imaging System for the Planning & Development office to Corporate Business Systems. We appreciate you participating in the bidding process and look forward to working with you.

Sincerely,

Bill Barnett  
Western Commissioner

Ray Weter  
Presiding Commissioner

Sue Ann Childers  
Eastern Commissioner

Attachment: 2-25-16 Bid Letters to Copier CO (2809 : Bid Decision-Color Digital Imaging System)





# CHRISTIAN COUNTY COMMISSION

100 W Church Street, Room 100

Ozark, Missouri 65721

Phone: 417-582-4300 • Fax: 471-581-5924

**Ray Weter**  
Presiding Commissioner

**Bill Barnett**  
Western Commissioner

**Sue Ann Childers**  
Eastern Commissioner

February 25<sup>th</sup>, 2016

Kent John  
American Business Systems  
416 South Jefferson  
Springfield, MO 65806

Dear Kent,

The Christian County Commission voted today in session to award the bid for a Digital Imaging System for the Planning & Development office to Corporate Business Systems. We appreciate you participating in the bidding process.

Sincerely,

		
Bill Barnett Western Commissioner	Ray Weter Presiding Commissioner	Sue Ann Childers Eastern Commissioner

Attachment: 2-25-16 Bid Letters to Copier CO (2809 : Bid Decision-Color Digital Imaging System)



# CHRISTIAN COUNTY COMMISSION

100 W Church Street, Room 100  
Ozark, Missouri 65721  
Phone: 417-582-4300 • Fax: 471-581-5924

**Ray Weter**  
Presiding Commissioner

**Bill Barnett**  
Western Commissioner

**Sue Ann Childers**  
Eastern Commissioner

February 25<sup>th</sup>, 2016

Tiffany Wood  
Lakeland Office System  
2932 E. Pythian Street  
Springfield, MO 65802

Dear Tiffany,

The Christian County Commission voted today in session to award the bid for a Digital Imaging System for the Planning & Development office to Corporate Business Systems. We appreciate you participating in the bidding process.

Sincerely,

Bill Barnett  
Western Commissioner

Ray Weter  
Presiding Commissioner

Sue Ann Childers  
Eastern Commissioner

Attachment: 2-25-16 Bid Letters to Copier CO (2809 : Bid Decision-Color Digital Imaging System)



# CHRISTIAN COUNTY COMMISSION

100 W Church Street, Room 100  
Ozark, Missouri 65721  
Phone: 417-582-4300 • Fax: 471-581-5924

**Ray Weter**  
Presiding Commissioner

**Bill Barnett**  
Western Commissioner

**Sue Ann Childers**  
Eastern Commissioner

February 25<sup>th</sup>, 2016

Rob Gentry  
Springfield Blue Print  
219 E. Pershing  
Springfield, MO 65806

Dear Rob,

The Christian County Commission voted today in session to award the bid for a Digital Imaging System for the Planning & Development office to Corporate Business Systems. We appreciate you participating in the bidding process.

Sincerely,

		
Bill Barnett	Ray Weter	Sue Ann Childers
Western Commissioner	Presiding Commissioner	Eastern Commissioner

Attachment: 2-25-16 Bid Letters to Copier CO (2809 : Bid Decision-Color Digital Imaging System)

## Resolution No. 2-25-2016-1

**SECTION 504/ADA POLICY & GRIEVANCE PROCEDURE**

The *County* of Christian has adopted an internal grievance procedure providing for prompt and equitable resolution of complaints alleging any action prohibited by the Americans With Disabilities Act (ADA) and implementing Section 504 of the Rehabilitation Act of 1973 as amended (29 U.S.C. 794). Section 504 states, in part, that “no otherwise qualified individual with a disability.....shall, solely by reason of her or his disability, be excluded from the participation in, be denied the benefits of, or be subjected to discrimination under any program or activity receiving Federal financial assistance.”

1. Complaints should be addressed to the County Administrative Assistant for the County Commission, as designated by the *County* to coordinate Section 504/ADA compliance efforts. Complaints should be filed in writing or verbally, contain the name and address of the person filing it, and briefly describe the alleged violation of the regulations.
2. A complaint should be filled within 10 days after the complainant becomes aware of the alleged violation. (Processing allegations of discrimination that occurred before this grievance procedure was in place will be considered on a case-by-case basis.)
3. An investigation, as may be appropriate, will follow a filing of a complaint. The Section 504/ADA Coordinator will be in charge of the investigation. These rules contemplate informal but thorough investigations that afford all interested persons and their representatives an opportunity to submit evidence relevant to a complaint.
4. A written determination as to the validity of the complaint and a description of the resolution, if any, will be issued by the Section 504/ADA Coordinator and a copy forwarded to the complainant no later than 30 days after its filing.
5. The Section 504/ADA Coordinator will maintain the files and records of the *County* relating to the complaints filed.
6. The complainant can request a reconsideration of the case in instances where he/she is dissatisfied with the resolution. The request for reconsideration should be made within 10 days to the *Presiding Commissioner*.
7. Using the grievance procedure is not a prerequisite to the pursuit of other remedies, including the filing of a Section 504 or ADA-related complaint with the responsible Federal department or agency.
8. These rules will be construed to protect the substantive rights of interested persons, meet appropriate due process standards, and assure that the *County* complies with the ADA, Section 504 and all implementing regulations.

This procedure was adopted by the *County* of Christian on the 25th day of February, 2016.

		
Bill Barnett Western Commissioner	Ray Weter Presiding Commissioner	Sue Ann Childers Eastern Commissioner





Attachment: 2-25-16 Ozark Kiosk on Square (2811 : Square Beautification)



CITY OF OZARK WAYFINDING SIGNS TYPICAL HEADER

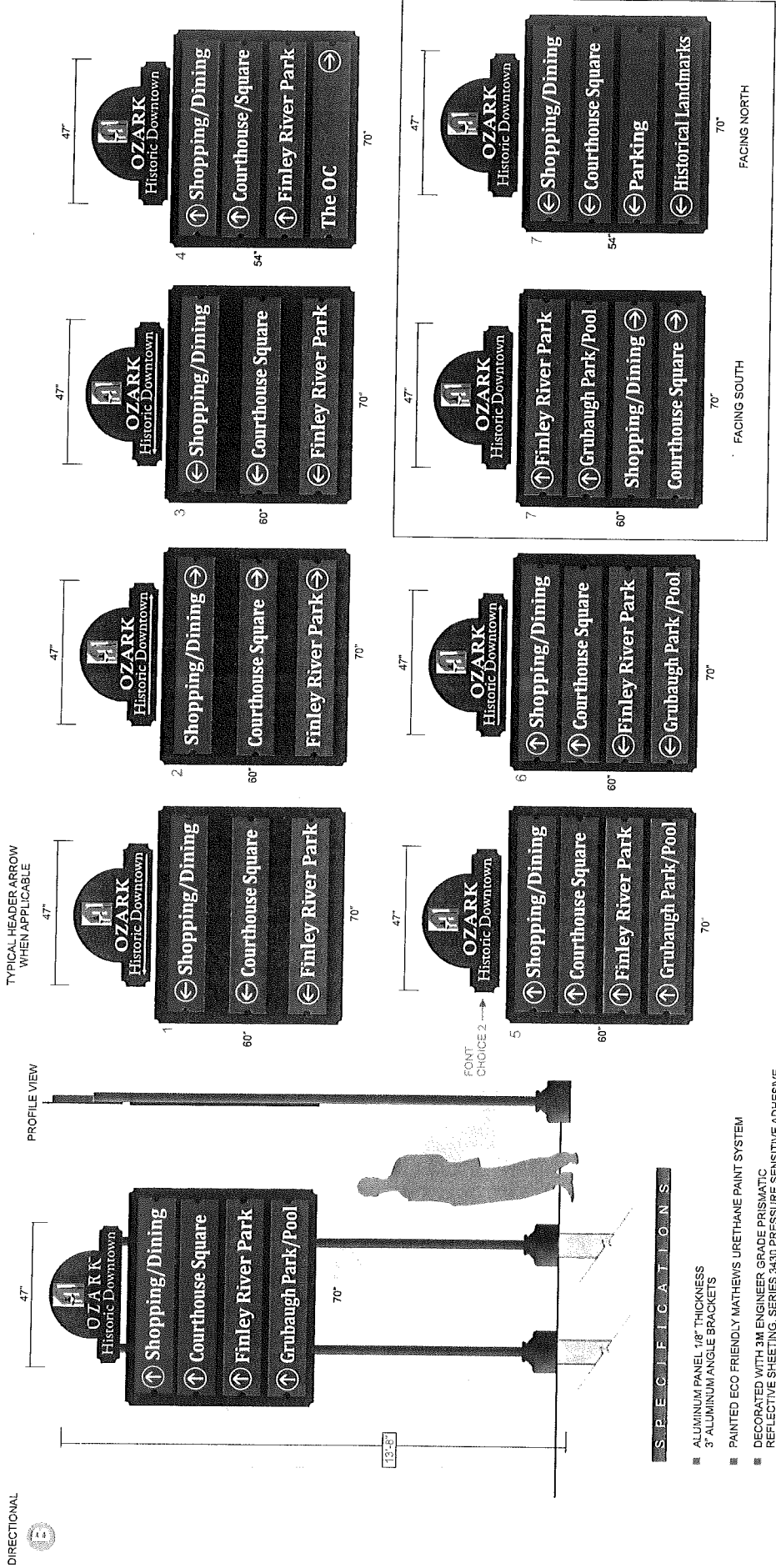

**S P E C I F I C A T I O N S**

- ALUMINUM PANEL 1/8" THICKNESS
- 3" ALUMINUM ANGLE BRACKETS
- PAINTED ECO FRIENDLY MATHEWS URETHANE PAINT SYSTEM
- DECORATED WITH 3M ENGINEER GRADE PRISMATIC REFLECTIVE SHEETING, SERIES 34-30 PRESSURE SENSITIVE ADHESIVE
- INSTALLS TO MODOT SPECIFIED BREAK AWAY SYSTEM (SEE PAGE 2)

**MISSOURI NEON COMPANY**  
Pride Through Quality  
8 Kennedy Springfield, MO 65803 417.882.1375 1.800.788.1778

**Green**

**30 Year**

Salesperson: Mike Scott File Path: Art Files/Mike Scott/City of Ozark  
Customer: Approver: \_\_\_\_\_  
Date: \_\_\_\_\_  
Date: \_\_\_\_\_  
Date: \_\_\_\_\_

Date: 6.11.14  
Revision #

UL

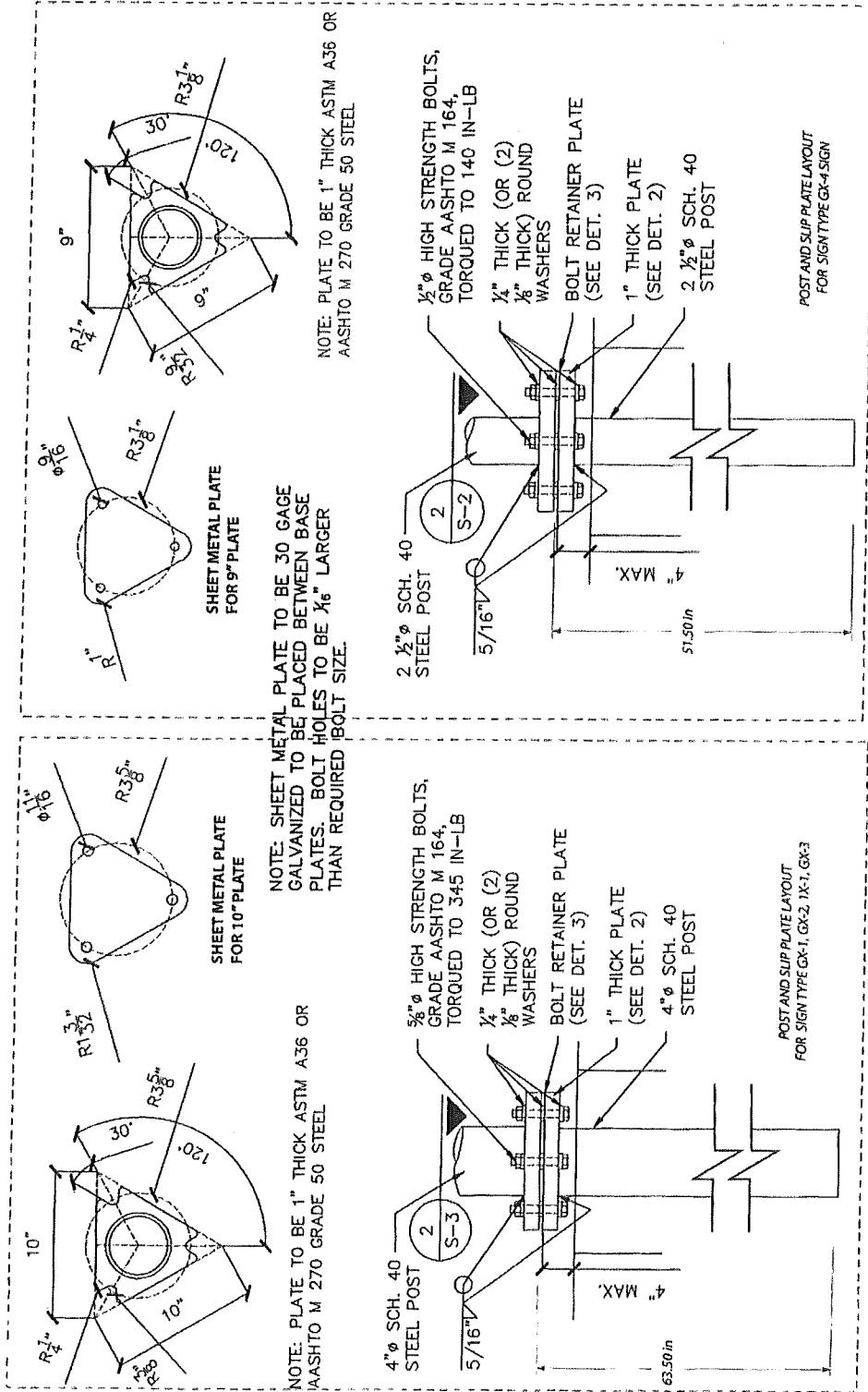

Date: 11.17.12

Revision #



Salesperson: Billie Scott File Path: Art Files/Billie Scott/ City of Ozark

Customer Approval

Date



**MISSOURI NEON COMPANY**  
Pride Through Quality  
1105 W. Central Expressway, P.O. Box 1000, Springfield, MO 65804 • 417-762-1331 • 1-800-378-7733